

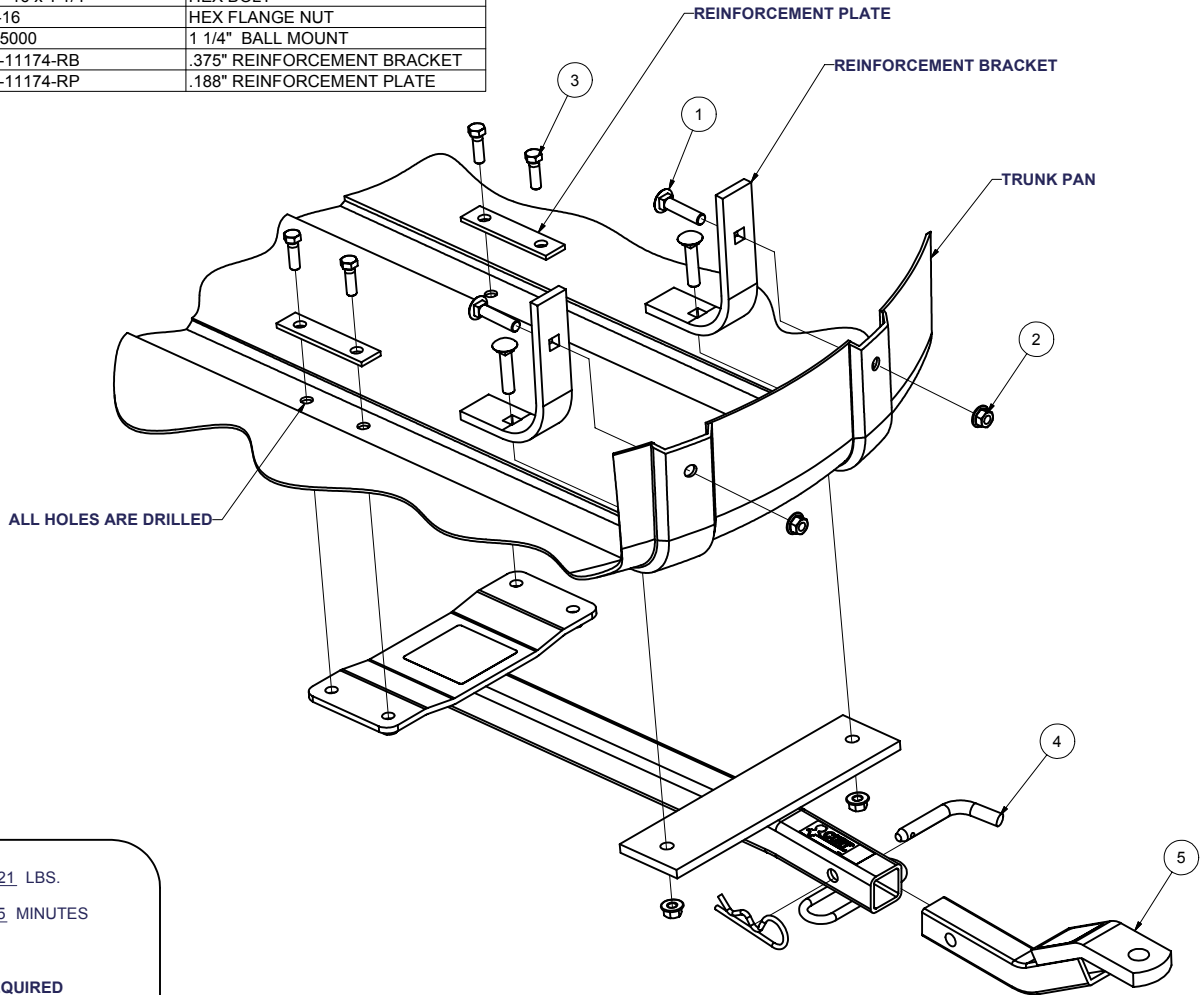

# 11174 BMW 300 SERIES SEDAN, COUPE, AND WAGON

GROSS LOAD CAPACITY WHEN USED AS A WEIGHT CARRYING HITCH: 2,000 LBS. TRAILER WEIGHT & 200 LBS. TONGUE WEIGHT.  
**\*\*\*DO NOT EXCEED VEHICLE MANUFACTURER'S RECOMMENDED TOWING CAPACITY.\*\*\***

Parts List			
ITEM	QTY	PART NUMBER	DESCRIPTION
1	4	7/16-14 x 2	CARRIAGE BOLT
2	4	7_16-14	HEX LG. FLANGE NUT
3	4	3/8 - 16 x 1 1/4	HEX BOLT
4	4	3/8-16	HEX FLANGE NUT
5	1	D-55000	1 1/4" BALL MOUNT
6	2	CM-11174-RB	.375" REINFORCEMENT BRACKET
7	2	CM-11174-RP	.188" REINFORCEMENT PLATE



HITCH WEIGHT: 21 LBS.  
 INSTALL TIME: 45 MINUTES  
 INSTALL NOTES:  
**DRILLING REQUIRED**

## INSTALLATION STEPS

- 1) Temporarily remove all items from car's trunk. Place the two reinforcement brackets inside the tire well, each fitting in a body recess so plate centers are 9 3/4". The longer end of each bracket should be up against the rear wall of tire well so that edge of plate lines up with body lip detail.
- 2) Using the brackets as a template, mark, center punch, and drill tire well for four 7/16" carriage bolts.
- 3) Install the carriage bolts into bracket. Lift hitch into position under tire well and attach it to the two carriage bolts. Install the rest of the bracket fasteners as shown. It may be necessary to hold lower fascia away temporarily to tighten fasteners.
- 4) Using the hitch as a template, drill the remaining mounting holes, and install hardware as shown.
- 5) Torque all 7/16" hardware to 50 lb.-ft. and all 3/8" hardware to 30 lb.-ft.

**PERIODICALLY CHECK THIS RECEIVER HITCH TO INSURE THAT ALL FASTENERS ARE TIGHT AND THAT ALL STRUCTURAL COMPONENTS ARE SOUND.**

Curt Manufacturing Inc., warrants this product to be free of defects in material and/or workmanship at the time of retail purchase by the original purchaser. If the product is found to be defective, Curt Manufacturing Inc., may repair or replace the product, at their option, when the product is returned, prepaid, with proof of purchase. Alteration to, misuse of, or improper installation of this product voids the warranty. Curt Manufacturing Inc.'s liability is limited to repair or replacement of products found to be defective, and specifically excludes liability for incidental or consequential loss or damage.